

Antennas, Masts, Head amplifiers, Cables and Filters for a 143.050MHz Meteor Scatter Radar Receiver

1 Introduction

This article describes some options for amateur radio astronomers who wish to construct a practical, low cost receiver station to observe meteor scatter echoes from the French Graves space surveillance transmitter on 143.050MHz. The document should be read in conjunction with reference¹.

There are 5 components discussed in this article:

- Yagi antennas
- Mast head amplifiers
- Cables
- Filters
- Suitable portable masts

These are the components needed before the signal is passed to either a communications receiver or a Software Defined Radio (SDR) receiver such as the FUNcube Dongle².

Antennas, Masts, Head amplifiers, Cables and Filters for a 143.050MHz Meteor Scatter Radar Receiver

2 Yagi Antenna for 144MHz

2.1 Two antenna designs

It is fortuitous that the Graves radar operating frequency is so close to the 2m amateur band at 144MHz. This means that there are a good number of suitable antenna designs available on the internet and in various books.

Yagis are chosen at this frequency as they are cheap and easy to build, do not require close tolerance manufacture or assembly and have usable gain and beamwidths.

Two designs are discussed here: a three element and a seven element Yagi. The smaller antenna is easier to transport and support on a mast, but has less gain. The beamwidth of the 3 element design is of course greater than that for the 7 element version and this may have advantages in meteor scatter observations as a larger area of sky is covered.

2.2 A three element Yagi

This is a very simple, easy to build antenna. Two good sources of design information are found in references ^{3,4}. What follows is based on these designs. In Figure 2.1 we see the antenna dimensional diagram from Southgate amateur radio news website.

The Southgate article makes a number of points relevant to the construction of this antenna which are reproduced below.

"A coaxial matching stub is used to match the driven dipole element to 50 ohms due to the coupling effect of the other elements.

Attach a length of approx 20cm RG58 coax at the feedpoint of the dipole (in parallel with the feeder cable and leave it open ended).

Some trimming will no doubt be needed of the matching stub for best match. I find it best to start off with a slightly longer length than required and trim by 5 mm each time. It is essential to trim by 5mm because the exact point of matching is quite narrow.

Expect 7db forward gain from the antenna.

You may vary the length of the driven element slightly and it will not impair performance, but you will have a slightly different length needed for the tuning stub."

Antennas, Masts, Head amplifiers, Cables and Filters for a 143.050MHz Meteor Scatter Radar Receiver

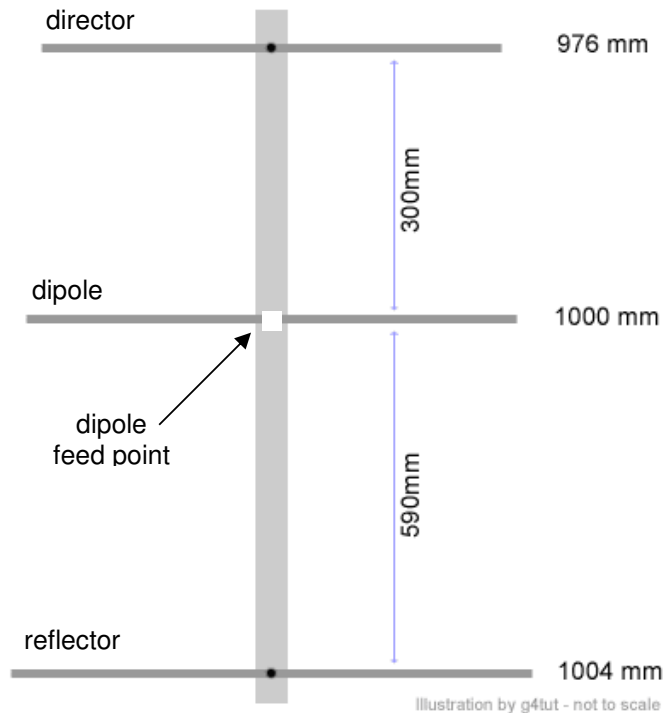

Figure 2.1 A 3 element simple Yagi antenna
© Southgate Amateur Radio

This antenna has been used quite successfully detecting radar echoes without the use of the impedance matching stub and can be omitted by beginners who may not have equipment to measure RF impedances or Voltage Standing Wave Ratios (VSWR).

A second design is detailed in reference³ developed by G4CQM. Originally designed for the 144 – 146 MHz amateur radio band, this is a rather professional looking antenna as shown in Figure 2.2. It is very well constructed and claims to have a natural feed point impedance of 50 Ω so that it is inherently well matched to 50 Ω coaxial cable. A detail of the dipole feed point connection is shown in Figure 2.3.

Antennas, Masts, Head amplifiers, Cables and Filters for a 143.050MHz Meteor Scatter Radar Receiver

© G4CQM



Figure 2.2 A 144MHz 3 element Yagi by G4CQM

In Figure 2.3 a ferrite choke ring (blue) can be seen around the cable. This is a device that helps prevent RF current from flowing on the outer shield of the coaxial cable which can alter antenna characteristics with cable disposition and height above ground – leading to variable performance.

© G4CQM



Figure 2.3 Direct connection to dipole feed point

Antennas, Masts, Head amplifiers, Cables and Filters for a 143.050MHz Meteor Scatter Radar Receiver

The designer has since modified the antenna to optimise performance at 143 MHz and to allow use of readily available materials. The new dimensions are:

<u>Element Position</u>	<u>Element Length</u>
0	Reflector = 1076 mm
265 mm	Driven Element = 973 mm
500 mm	D1 = 836 mm

The antenna is expected to produce a forward gain of 4.6 dBd and better than 17 dB front to back ratio (F/B).

G4CQM makes the following points:

“The Yagi is what I call a 'Flat Liner', having a broad frequency response, gain and impedance characteristic. Finally, remember that this design is based on FREESPACE dimensions, so make sure the elements are either mounted on insulators above the boom or use a non-metallic boom! Use either 5/8 inch or 15 mm OD pipe/tubing for the elements. The Driven Dipole Element dimension is end to end, so cut two pieces 479 mm long and provide a 15 mm gap.”

The antenna is expected to have a beamwidth of $\sim 70^\circ$ as shown in Figure 2.4. In practice the antenna may have a slightly wider beamwidth with less pronounced nulls than shown in the modelling.

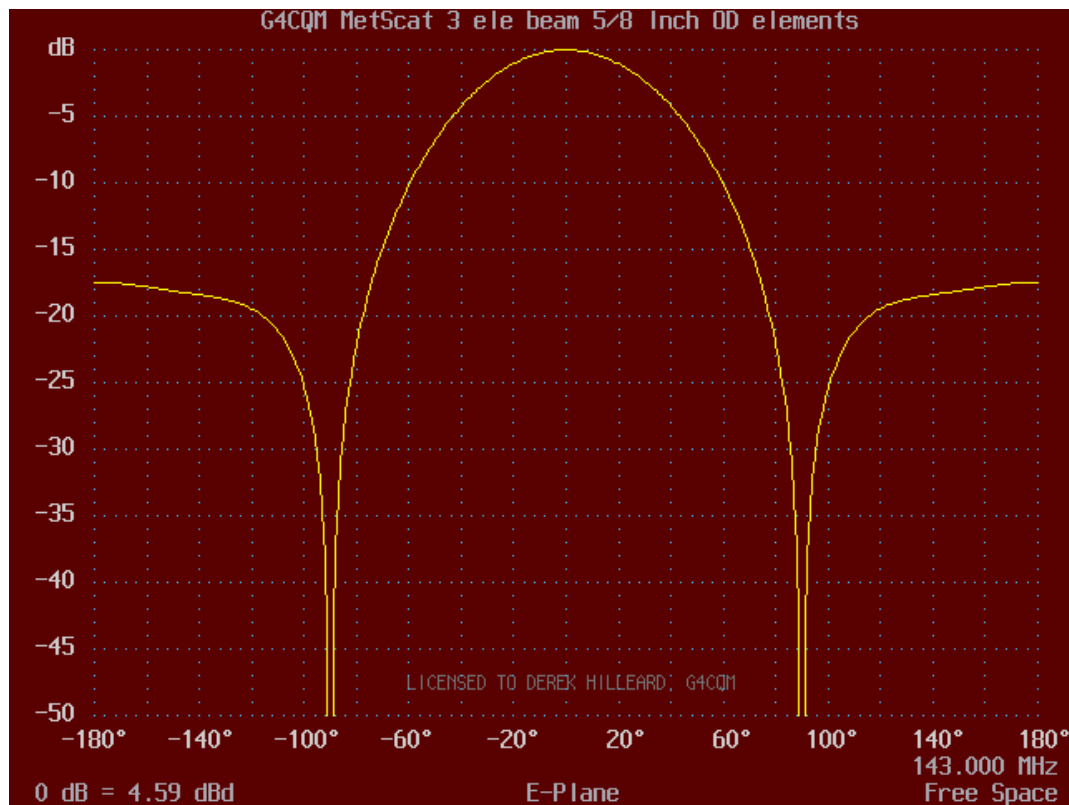

Figure 2.4 Expected -3dB antenna beamwidth
© G4CQM

Antennas, Masts, Head amplifiers, Cables and Filters for a 143.050MHz Meteor Scatter Radar Receiver

2.3 A 7 Element 144MHz Yagi

This design is more sophisticated than the previous antennas. With more elements, it has a higher gain and a narrower beam width. It also has the novel feature of a 'half folded dipole'. The design is by W7ZOI⁵ and has been built and tested by the author of this document.

The dimensioned drawing is shown in Figure 2.5.

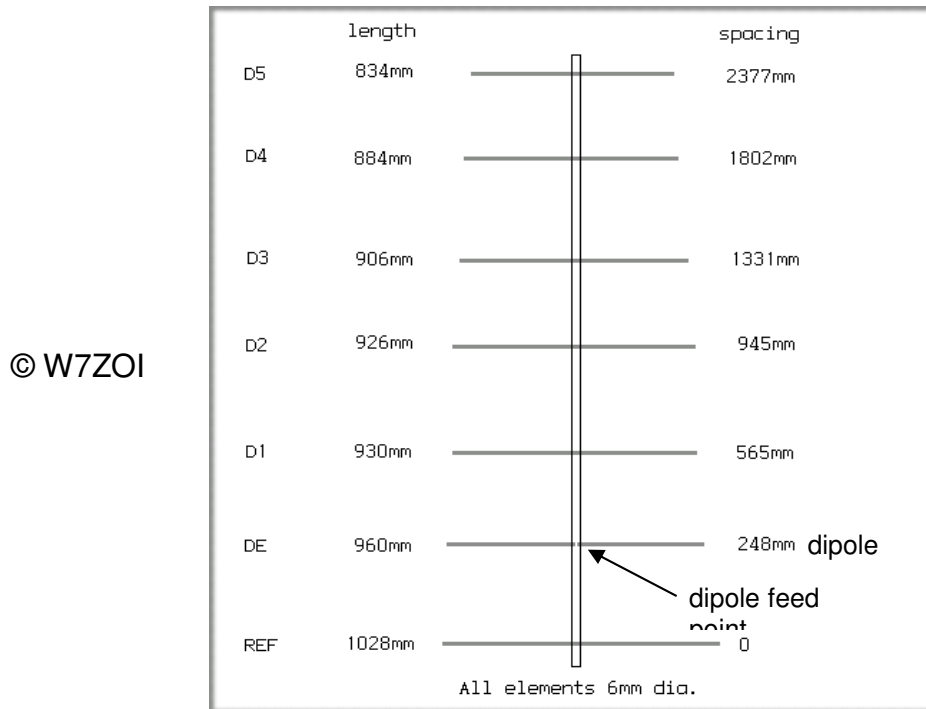

Figure 2.5 W7ZOI 144MHz 7 element Yagi

Detail of the driven element – the 'half folded dipole' is shown in Figure 2.6.

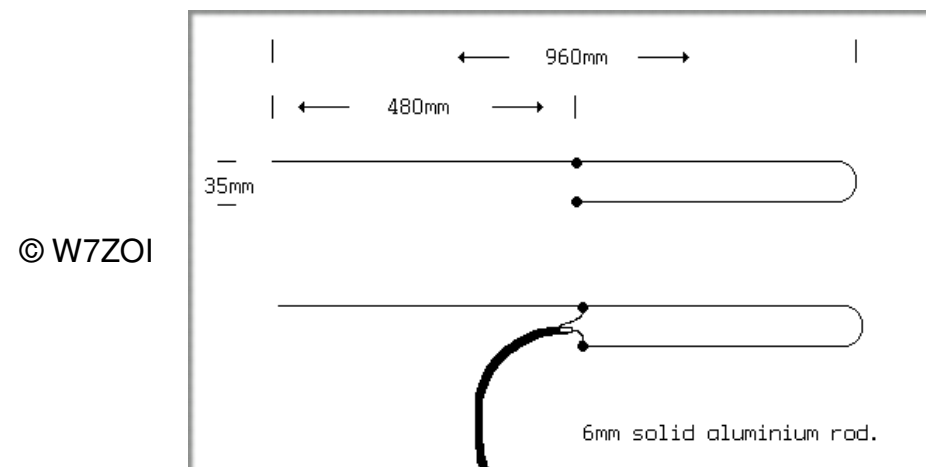

Figure 2.6 Detail and connection to the driven element

Antennas, Masts, Head amplifiers, Cables and Filters for a 143.050MHz Meteor Scatter Radar Receiver

W7ZOI comments that “This design offers a good compromise between maximum gain, a clean pattern and good front to back ratio. In free space, the driven element would have a feedpoint impedance of about 150 Ohms. The effect of the parasitic elements reduces the impedance to somewhere in the region of 50 Ohms. The measured SWR is 1.1:1 at 144.300MHz and well under 1.5:1 across the entire 2M band (144 to 146MHz). The results of on-air tests with other amateurs suggest that the performance of the portable Yagi is very close to the NEC computer model performance prediction. Most stations reported an F/B ratio of about 25dB.”

The predicted polar diagram for this antenna is shown in Figure 2.7.

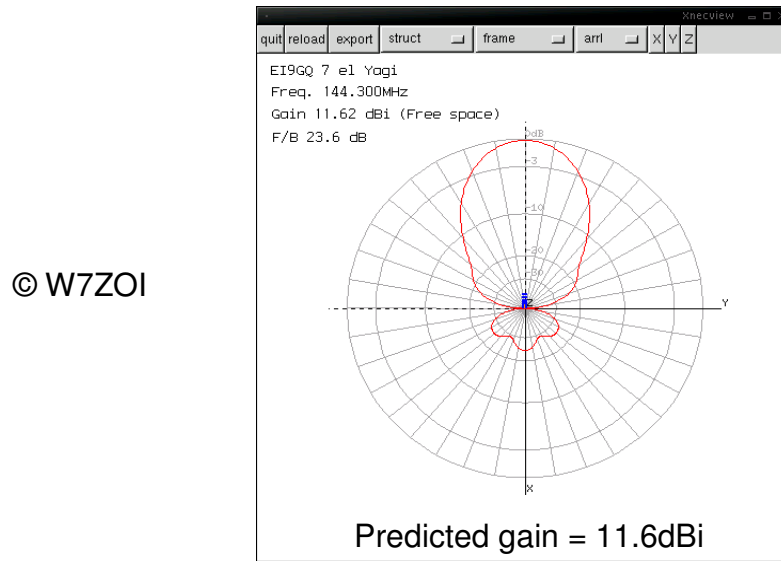

Figure 2.7 Predicted Polar diagram for W7ZOI 7 element Yagi

A picture of the connection of the coaxial cable to the driven element is shown in Figure 2.7.



Figure 2.7 Cable connection to driven element

Antennas, Masts, Head amplifiers, Cables and Filters for a 143.050MHz Meteor Scatter Radar Receiver

This antenna was constructed by the author and is shown in Figure 2.8. A crude measurement was made (in an open area) of the forward 180° of the polar diagram and is shown in Figure 2.10.



This shows the author's antenna built to the W7ZOI design. The antenna is constructed on a varnished wooden boom with aluminium elements, except for the driven element which is copper.

It is easy and cheap to construct and performed well when used to observe meteor scatter echoes from the Graves radar at 143.050MHz.

The frequency response of the antenna when measured on an open field site is shown in Figure 2.9 with a useful bandwidth of 14 MHz from 135.5MHz to 149.5MHz.

Figure 2.8 7 Element 144MHz Yagi

The centre frequency is 142.5MHz, slightly lower than the design value.

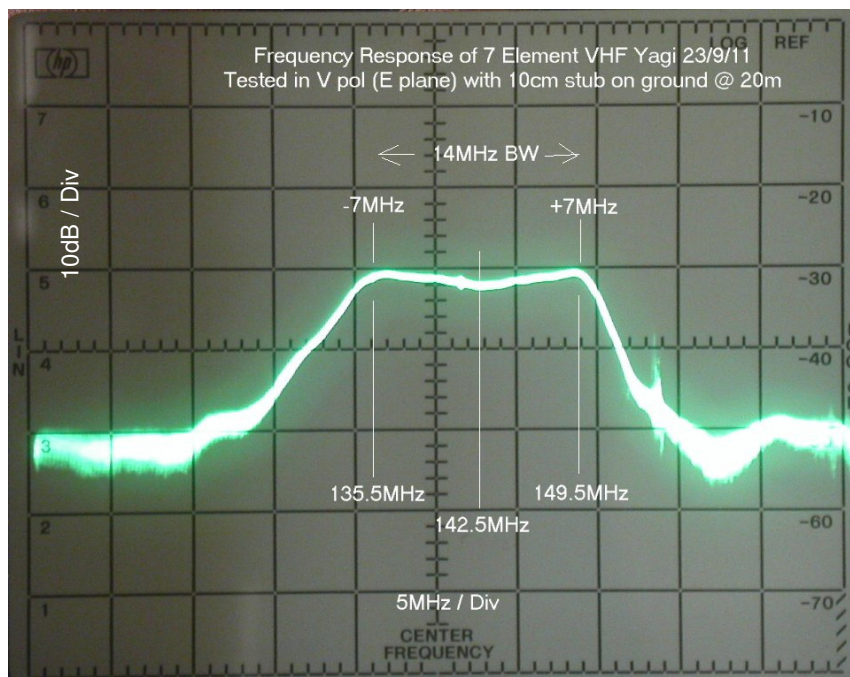

Figure 2.9 Frequency response of 7 Element Yagi

Antennas, Masts, Head amplifiers, Cables and Filters for a 143.050MHz Meteor Scatter Radar Receiver

The antenna beam diagram in Figure 2.10 was measured on an open range and shows some asymmetry in the sidelobes which are ~ 20dB down on the main beam. The -3dB beamwidth is ~ 50 °.

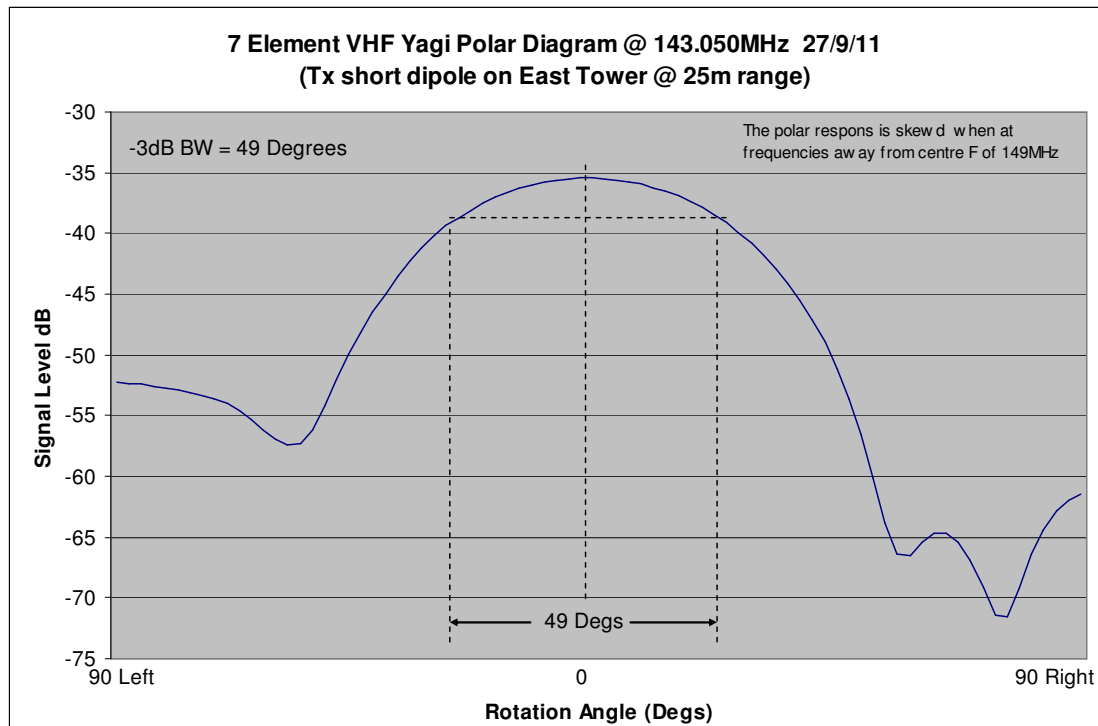

Figure 2.10 7 Element Yagi Antenna Beam Pattern

As mentioned earlier, this antenna proved to be very satisfactory in receiving meteor scatter echoes on 143.050MHz when mounted on a 6m mast and pointed to the south east toward the Graves transmitter.

2.4 An assessment of 3 and 7 element Yagi designs

Either antenna can be used for detecting meteor echoes. The 3 element is more compact and can be fitted into a car or other small vehicle, which means it can be used in a variety of locations.

It has a broad beamwidth of 70 ° and a gain of 7dBi. During tests it was found to receive a greater number of echoes than the 7 element antenna but produced lower signal strengths.

The 7 element Yagi is larger and heavier than the 3 element and is difficult to fit into a car. It has a gain of 11dBi and a narrower beamwidth of 50 °. Fewer echoes were detected per minute than with the 3 element antenna, but the signals were significantly stronger.

Further information on Yagi antenna design can be found at references ^{6,7}.

Antennas, Masts, Head amplifiers, Cables and Filters for a 143.050MHz Meteor Scatter Radar Receiver

3 Mast head amplifiers

If the antenna is to be sited more than 20m from the receiver it is probably necessary to incorporate a mast head amplifier to compensate for the cable loss. It should be mounted at the top of the mast with only a short length of coaxial cable to the antenna. It will need protecting from the weather and be supplied with power via a separate cable, or using a bias T to enable the supply voltage to be fed into the coaxial cable carrying the RF signal. Designs for a bias T can be found at ⁸.

A suitable amplifier can be constructed or purchased from a number of suppliers. An example shown below is from 'mini circuits' ⁹.

It has a wide frequency response from 10 MHz to 3GHz and can be employed for other purposes when not being used for meteor observations. The gain is 22dB @ 144MHz and it has a low noise figure of ~ 1dB. See Figures 3.1 & 3.2.

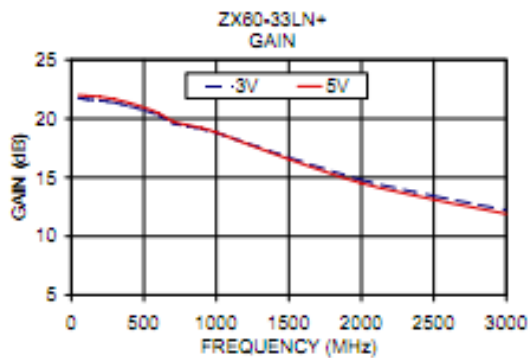

Figure 3.1 ZX60-33LN-S+ Gain

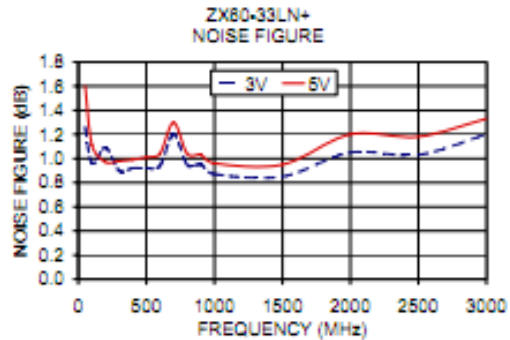

Figure 3.2 ZX60-33LN-S+ Noise figure
© Mini circuits

The mini circuits' device is shown in Figure 3.3 (the connectors are SMA)

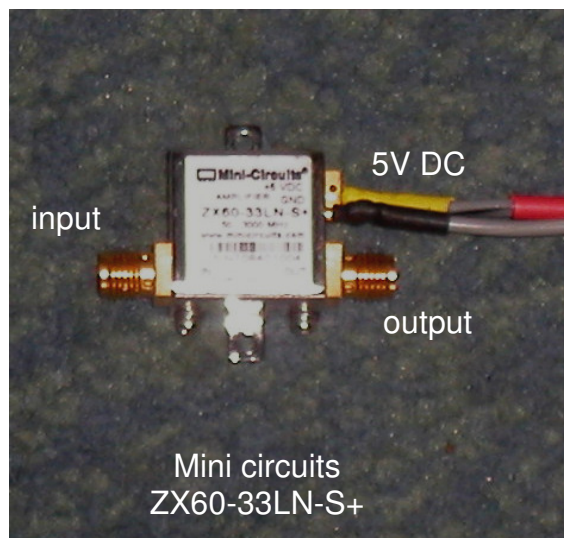

Figure 3.3 ZX60-33LN-S+ device

Antennas, Masts, Head amplifiers, Cables and Filters for a 143.050MHz Meteor Scatter Radar Receiver

An example of mounting the head amplifier close to the dipole element in the antenna is shown in Figure 3.4 & 3.5.

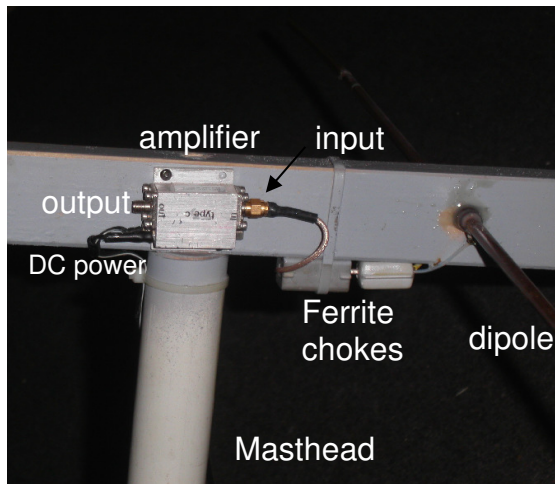

Figure 3.4 Mast head Amplifier

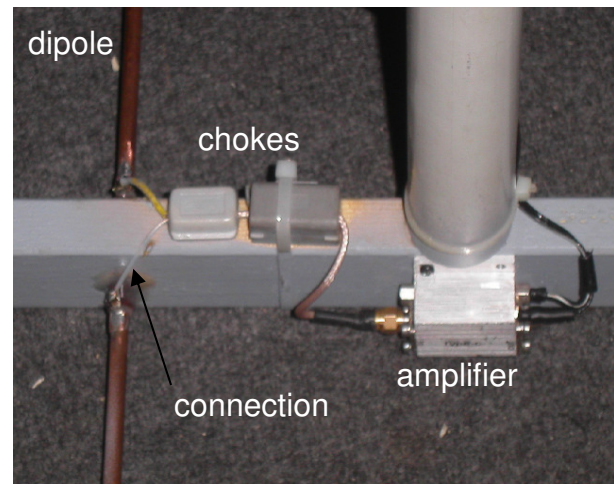

Figure 3.5 Amplifier - RF Chokes & dipole

Antennas, Masts, Head amplifiers, Cables and Filters for a 143.050MHz Meteor Scatter Radar Receiver

4 Cables

4.1 Cable types

A wide variety of coaxial cables can be obtained ^{10, 11} varying in quality and price. For operation at VHF (143.050MHz) very expensive low loss cable is probably not required unless very long lengths (> 30m) are being used. A suitable mid priced cable is URM 76 costing in the region of £47/100m* with an attenuation of 2.3dB/10m @200MHz¹⁰.

A higher quality, double-screened cable is RG223 at £164 /100 m*. It has an attenuation of 1.9dB / 10m @ 200MHz ¹⁰.

BNC connectors are adequate for terminating these cables. A whole range of connectors is available from RS Components ¹⁰ and other major suppliers¹¹.

* December 2011 prices from reference ¹⁰.

Antennas, Masts, Head amplifiers, Cables and Filters for a 143.050MHz Meteor Scatter Radar Receiver

5 Filters

5.1 The purpose of Filters

The RF spectrum is crowded with transmissions of various types and strengths. The VHF band is densely populated with many high power broadcast stations and communications channels - both digital and analogue. The Graves radar frequency is also close to the 2m amateur radio band. Pagers are a particular problem and operate quite close to 143MHz.

When attempting to detect a meteor scatter radar echo from over 1100km away in southern France, the signal strength will be low and close-by stations, such as the Pagers, can easily cause overloading of the receiver front end or the mast head amplifier. A high pass, low pass or, better, a band pass filter is often required to minimise the problem of overloading by out of band signals.

There is no single solution that will fit all circumstances. The type of filter best suited to reduce interference depends on the receiver being used, the location of the site, the strength of particular nearby transmitters, the gain and beamwidth of the antenna being used and the direction in which it is pointing.

In general a band pass filter centred on 143.050 MHz (or the frequency of whichever over-the-horizon transmitter is being used for observations) is the best option. However, commercial narrowband filters are usually bespoke orders and can be expensive. Home constructed filters are a good option if one has some skill in electronic fabrication.

5.2 A 2m Band pass Filter

A very useful filter design for the 2m band is given by ¹² incorporating 3 Pi section filters shown in Figure 5.1.

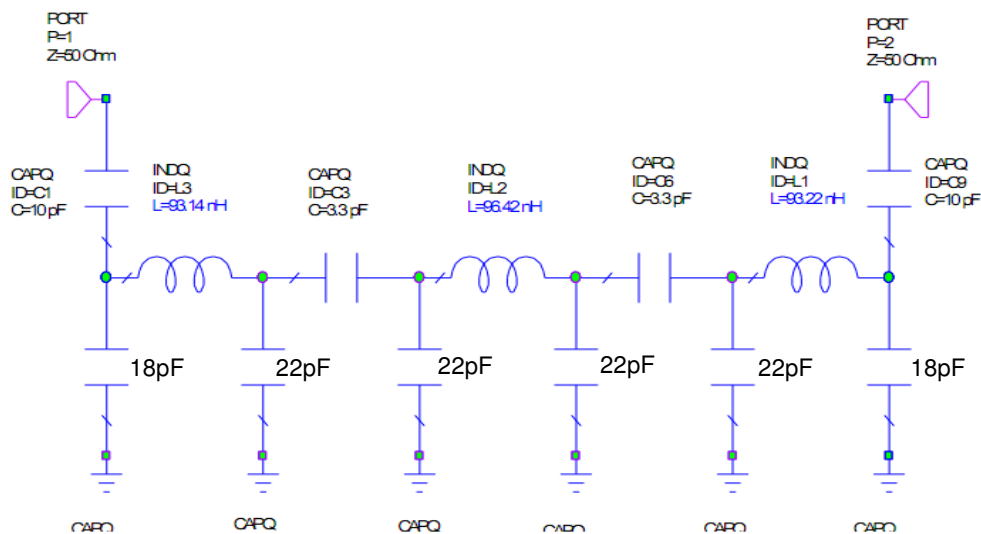
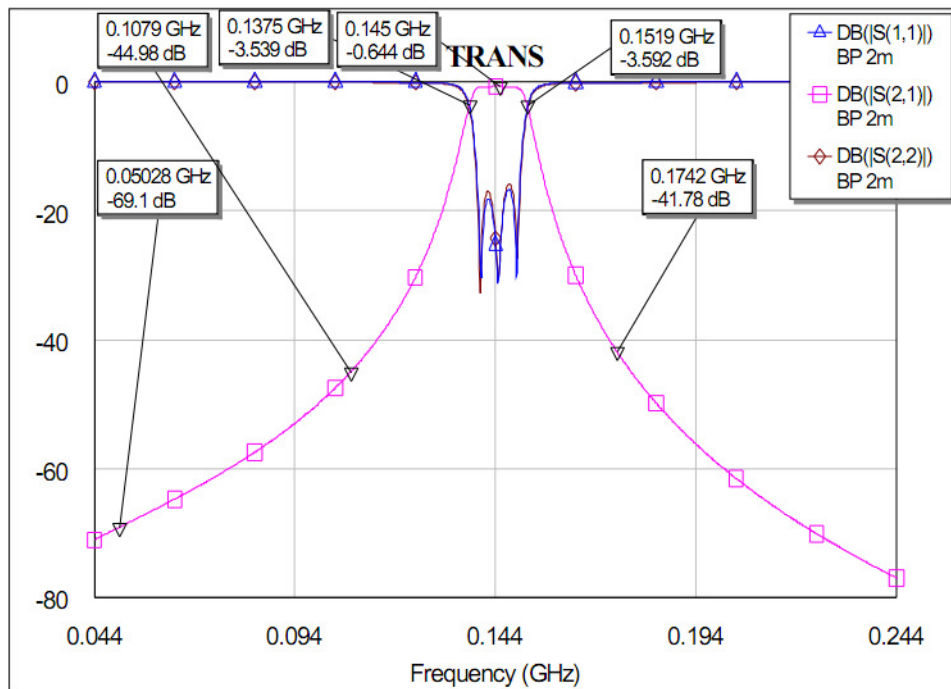

Figure 5.1 2m band pass filter by Dipl ing Tasić Siniša –Tasa YU1LM/QRP © YU1LM

Antennas, Masts, Head amplifiers, Cables and Filters for a 143.050MHz Meteor Scatter Radar Receiver

YU1LM gives the response shown in Figure 5.2 for this filter design. This is almost ideal for use with a Graves meteor scatter radar receiver.



Amplitude frequency response for real C capacitors from Murata and real Q inductors
L= self support isolated copper wire diameter 1mm (AVG18) wound at 5 mm 6 turn
close wound length 6mm Qo=350 and Frez=901 MHz.

*Figure 5.2 Frequency response of YU1LM 2m band pass filter
© YU1LM*

The author of this document has built a filter to this design and it is shown in Figure 5.3. A brass tuning slug has been incorporated for fine tuning of the band pass frequency and insertion loss.

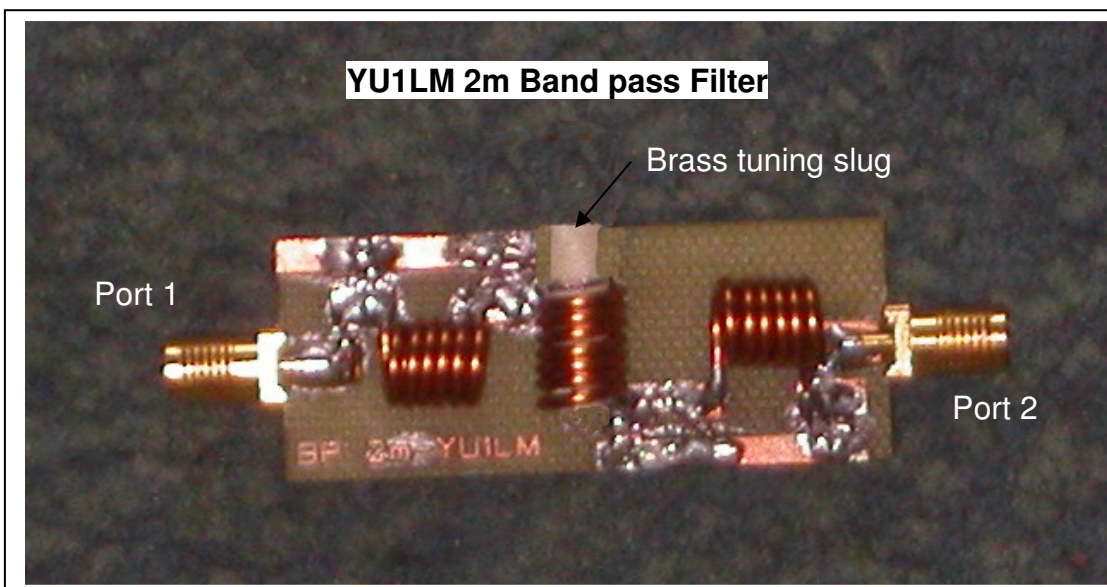

Figure 5.3 A YU1LM 2m band pass filter built on PCB

Antennas, Masts, Head amplifiers, Cables and Filters for a 143.050MHz Meteor Scatter Radar Receiver

The measured band pass profile of the filter in Figure 5.3 is shown in Figure 5.4. The lower edge is at 133 MHz : the upper edge is at 143.1 MHz and the insertion loss is 3 dB. The insertion loss is greater than that predicted from circuit modelling, but does not prevent the filter being useful as part of a meteor scatter receiver.

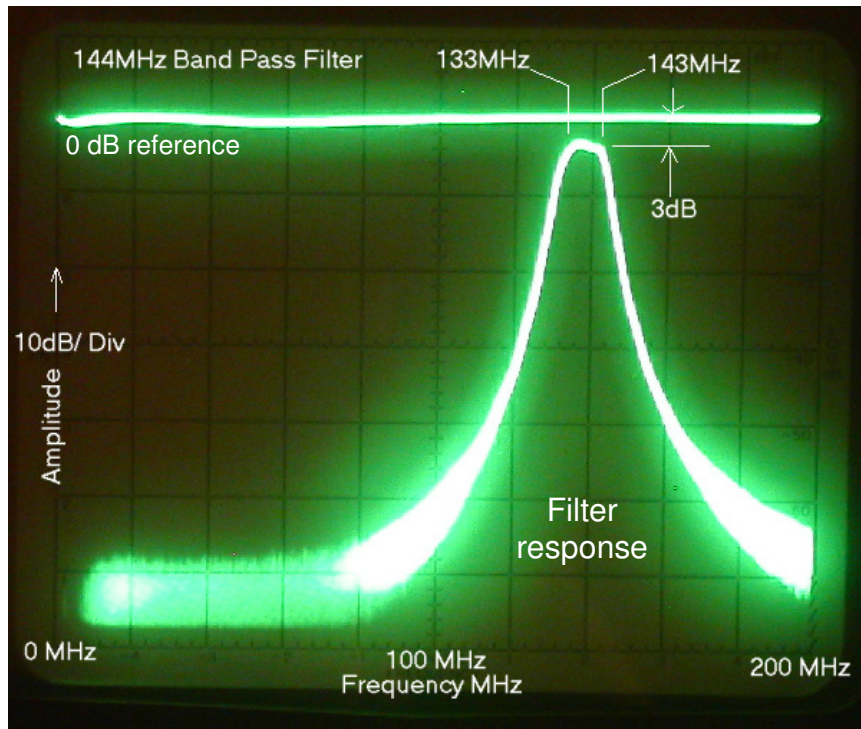

Figure 5.4 Measured response of YU1LM 2m band pass filter

5.3 Communications receivers and SDR FUNcube Dongle

In general, communications receivers have a selection of physical band limiting filters incorporated in their 'front end' design. This makes them relatively immune to nearby signal overloading and unpleasant intermodulation effects. An additional filter between the antenna and receiver may not be necessary when using a good quality communications receiver.

When using the FUNcube Dongle SDR device, a suitable filter is usually needed as the FUNcube front end is open across a wide band of frequencies. Intermodulation products can be generated in the presence of nearby transmissions with frequencies close to the observing frequency. The FUNcube has a good sensitivity and the added small loss from the filter will not be problem. It is recommended that a filter is always used with the FUNcube device. Whether the filter is placed before or after the head amplifier (if one is being used) will depend on the individual circumstances, but it is good practice to put it before the amplifier.

Antennas, Masts, Head amplifiers, Cables and Filters for a 143.050MHz Meteor Scatter Radar Receiver

6 Antenna Mast

6.1 Antenna height

The height at which a given antenna type should be above ground for best performance is a complex issue and depends on many variables¹³. For a simple dipole, reference¹³ has a graph as shown in Figure 6.1 where the dipole impedance (for both horizontal & vertical orientations) varies with height above the ground. When the antenna is λ above the ground the impedance settles to $\sim 75 \Omega$. It is suggested that the meteor scatter aerial should be at least 2λ above ground. At $\sim 2\text{m}$ wavelength this makes a mast height of 4m or more.

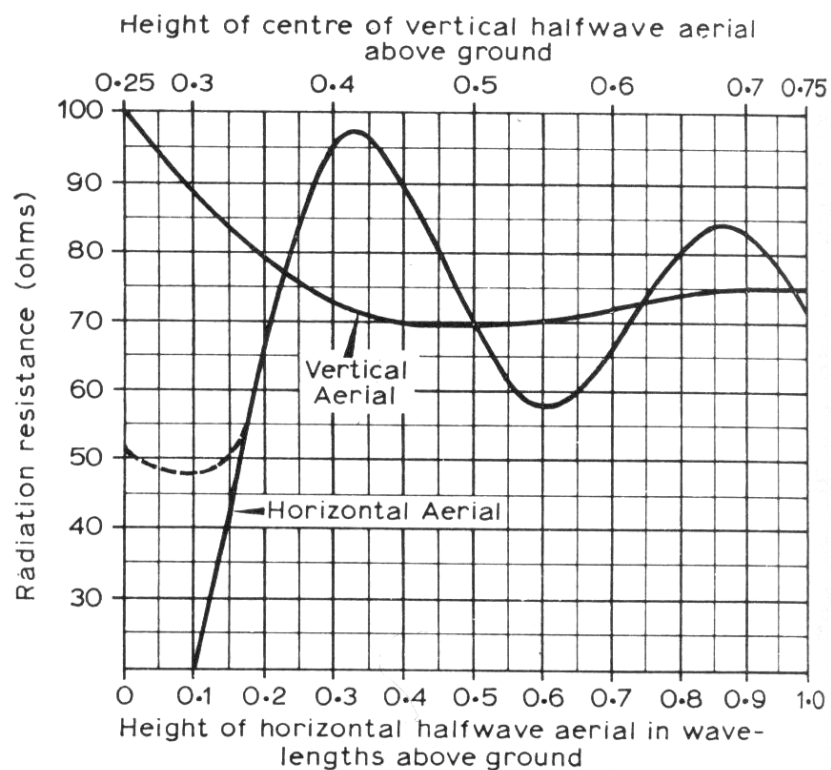

Fig 12.86. Radiation resistance of $\lambda/2$ horizontal and vertical dipoles as a function of height above a perfect earth.

Figure 6.1 Dipole impedance vs height above ground
© RSGB

6.2 Physical construction

If the meteor scatter receiver is to be in a fixed location, e.g. a house, the antenna can simply be mounted high up on the wall. If it is to be mobile, or transportable, then a mast and guy rope design is required. To be accommodated in most cars or on roof racks, the main support pole will need to be split into two sections each no less than 2m long. The poles can be joined in the middle by various means, including a clamped outer sleeve with dimensions slightly larger than the support poles. See Figure 6.2.

Antennas, Masts, Head amplifiers, Cables and Filters for a 143.050MHz Meteor Scatter Radar Receiver

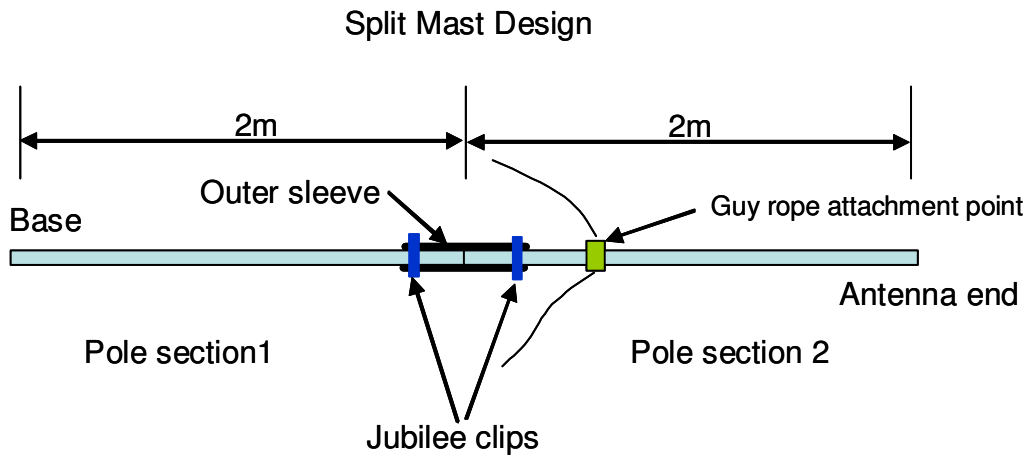

Figure 6.2 Suggestion for a split pole antenna mast



Figure 6.3 7 Element Yagi on a Mast

The mast design given above can be used to support either a 3 element or a heavier 7 element antenna as shown in this picture. The pole sections need to be about 50mm in diameter to be strong enough to cope with winds. The guy ropes should be made from 5mm nylon rope and staked to the ground with steel pegs at least 30cm long and 5mm diameter.

Unless the user wishes to rotate the antenna on the top of the mast a simple fixing can be used that will be robust against changing wind directions.

A mast head antenna rotator would be very useful if multiple over-the-horizon transmitters are to be used depending on the direction of a given meteor shower radiant.

Antennas, Masts, Head amplifiers, Cables and Filters for a 143.050MHz Meteor Scatter Radar Receiver

A close up view of the 7 element antenna with its head amplifier and weather protection mounted on the mast is shown in Figure 6.4.

A similar picture of the 3 element antenna is shown in Figure 6.5.



Figure 6.4 7 Element Yagi on mast



Figure 6.5 3 Element Yagi on mast

Antennas, Masts, Head amplifiers, Cables and Filters for a 143.050MHz Meteor Scatter Radar Receiver

7 Meteor echoes received with the 7 element Antenna

To complete this article some meteor echoes received with this equipment are shown below. The pictures are screen shots from SpectraVue software ¹⁴ and show the demodulated echo spectrum in green on the top trace with zero frequency to the left and 3kHz to the right. The amplitude is 10dB/div. Below this is a waterfall plot of the spectrum with earlier time to the bottom and later time to the top of the picture. The time axis is ~8 seconds long.

The meteor echo is the form in the middle of the waterfall plot. Plot #1 shows a simple falling tone with a persistent strong feature at zero velocity. #2 is a decelerating trail with modulation (probably due to trail diffraction). Plot 3 is a strong echo from a static meteor trail lasting several seconds

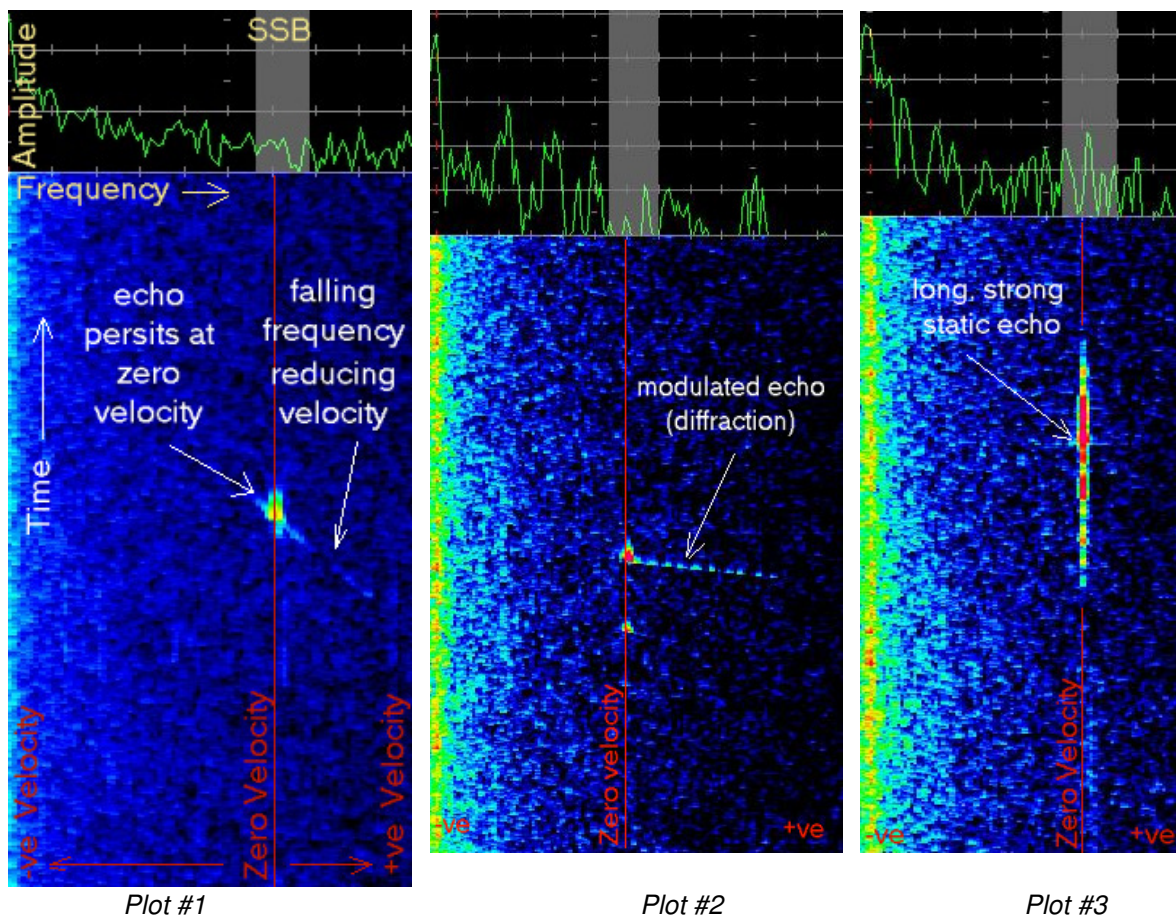

The echoes can also be analysed with Spectrum Lab software ¹⁵ and an interesting 'hook' echo is shown in Figure 6.7.

Antennas, Masts, Head amplifiers, Cables and Filters for a 143.050MHz Meteor Scatter Radar Receiver

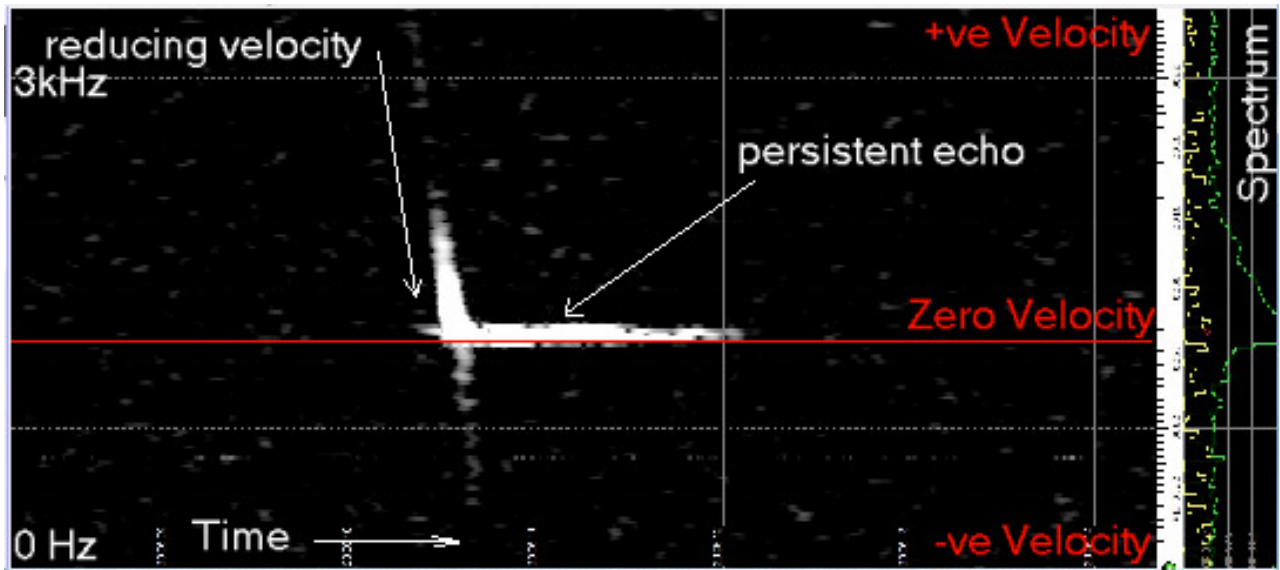

Figure 6.7 A 'hook' form of echo analysed with Spectrum Lab software

Antennas, Masts, Head amplifiers, Cables and Filters for a 143.050MHz Meteor Scatter Radar Receiver

8 Conclusions

This article has been written to aid those wishing to construct the physical elements of a meteor scatter receiver, ie the antenna, head amplifier, connecting cable and filter components. Wherever possible, low cost components and designs have been used to enable as many people as possible to engage in this activity.

A few points to note are as follows:

- Designs for 3 element and 7 element Yagi antennas are presented having been designed by a number of amateur radio enthusiasts for the 2m band.
- Gain, beamwidth and polar responses are presented to aid the observer in gauging what each antenna will 'see' when the beam shapes are 'mapped' on to the sky.
- The low gain 3 element designs will cover a wider area of sky than the 7 element design, but echo signals will be weaker.
- Using the higher gain 7 element antenna may result in fewer echo detections, but those will be strong signals with clear Doppler line of sight (LOS) frequency / time profiles.
- Both 3 element and 7 element designs have been built and used by the author with good results.
- If long cable runs are to be used (20m) it may be useful to include a mast head amplifier in the receiver set up. Details of a suitable commercial component are given, but many amateur radio enthusiasts will be capable of building their own device.
- Two examples of suitable coaxial cables and connectors are included in this document.
- The importance of band limiting filters is stressed, particularly if one is using the SDR FUNcube Dongle receiver. Pre-filtering is not so important if a good quality communications receiver is being used, as these usually have their own built-in filter sets.
- An easy to construct 2m band pass filter design is given. The author has constructed and used this filter with good effect with the FUNcube Dongle receiver.
- Finally, the design is suggested for an antenna mast capable of holding either the 3 or 7 element Yagi antennas at least 4m above the ground.

It is hoped that the information presented here, gathered from a wide range of sources, will assist amateur radio astronomers and others to engage in the detection of meteor scatter echoes – either from the Graves transmitter or other suitable VHF transmitters that are over the radio horizon.

Antennas, Masts, Head amplifiers, Cables and Filters for a 143.050MHz Meteor Scatter Radar Receiver

References

- 1 An SDR Meteor Radar & Detection of Meteors by Radar www.britastro.org/radio
- 2 FUNcube Dongle www.funcubedongle.com/
- 3 G4CQM Simple 3 element Yagi for 143 MHz
<http://g4cqm.www.idnet.com/CQMMS3/index.html>
- 4 Simple 3 element Yagi for 144MHz
http://www.lu1dma.com.ar/g4cqm/yagi_designs/4X1UN/index.htm
- 5 Portable 7 element Yagi for 144 MHz homepage.eircom.net/~ei9gg/yagi.html
- 6 Folded half dipole at many frequencies www.wa5vjb.com/yagi-pdf/cheapyagi.pdf
- 7 VHF / UHF Antenna designer www.k7mem.com/Electronic.../yagi_vhf_quick.html
- 8 Bias Tee http://en.wikipedia.org/wiki/Bias_tee
<http://www.minicircuits.com/products/BiasTees.shtml>
- 9 mini circuits www.minicircuits.com/
- 10 RS Components uk.rs-online.com
- 11 Farnell Components <http://uk.farnell.com/connectors>
- 12 2m Bandpass Filter <http://yu1lm.qrpradio.com/2m%20BP%20FILTER-YU1LM.pdf>
- 13 Radio Communications Handbook Fifth Edition p 12.56 ISBN 0 900612 58 4
- 14 SpectraVue Software www.moetronix.com/spectravue.htm
- 15 Spectrum Lab software www.qsl.net/dl4yh/spectra1.html